

Adjust Fold Chutes to the appropriate paper size and fold type by pulling black pegs up and place the fold stop to the corresponding chute setting then pushing the pegs back down. **Note: The Ameraseal-MR has been pre-set for 8.5 x 11 Z-fold documents. See "Fold and Chute Setting Matrix" below for other paper and fold combinations.**

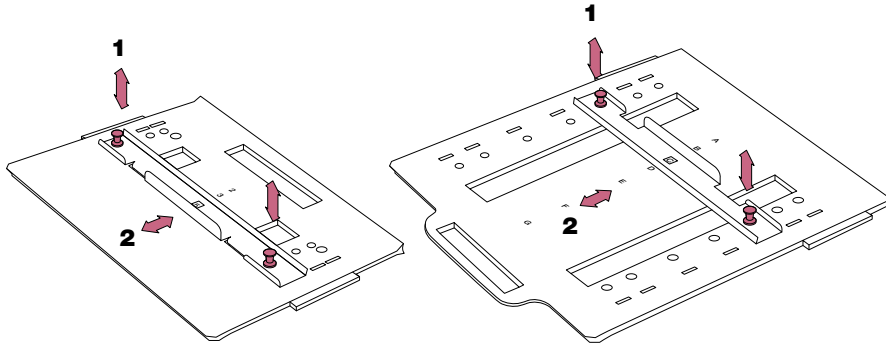

#### Fold Chute Settings Matrix

Paper Size	Fold Type	Upper Chute Setting	Lower Chute Setting	Document Orientation - Loading Printed Documents in Paper Tray*
8.5 X 11	Z-fold	5	B	Tear instructions face-down, at leading edge away from feeding roller
8.5 X 11	C-fold	5	E	Security panel face-up, at leading edge toward feeding roller
8.5 X 11	V-fold	Diverter**	D	Tear instructions face-up, at leading edge toward feeding roller
8.5 X 11	Ecc-Z-fold	4	A	Printed side face-up, short perforated panel at leading edge to roller
8.5 X 14	Z-fold	3	C	Tear instructions face-down, at leading edge away from feeding roller
8.5 X 14	C-fold	3	F	Security panel face-up, at leading edge toward feeding roller
8.5 X 14	Ecc-Z-fold	2	B	Printed side face-up, short perforated panel at leading edge to roller
8.5 X 14	Ecc-C-fold	1	H	Tear instructions face-up and AWAY FROM LEADING EDGE
8.5 X 14	Ecc-C-fold	2	G***	Tear instructions face-up and AWAY FROM LEADING EDGE

\* These orientations may vary by form manufacturer

\*\* This is the handle end of the Upper Chute

\*\*\* Check with form manufacturer

# Ameraseal-MR

## Quick Setup

**Ameraseal**<sup>TM</sup>

1-800-243-9757

[www.americanbus.com](http://www.americanbus.com)

1

Unpack the contents of the box. Remove any packing tape.

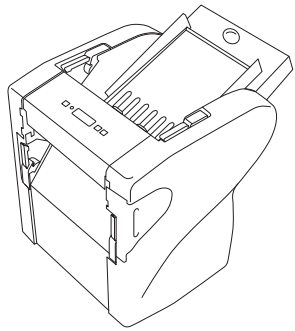

Ameraseal-MR  
Main Unit

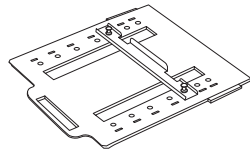

Lower Fold Chute  
(shown face up)

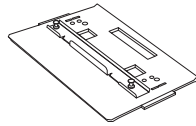

Upper Fold  
Chute/Diverter  
(shown face up)

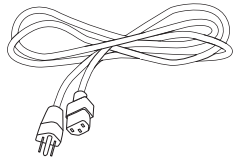

Power Cord

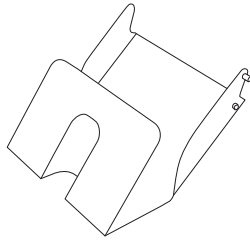

Exit Tray

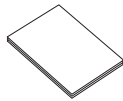

User Guide

2

Lift out upper and lower Fold Chute lock levers.

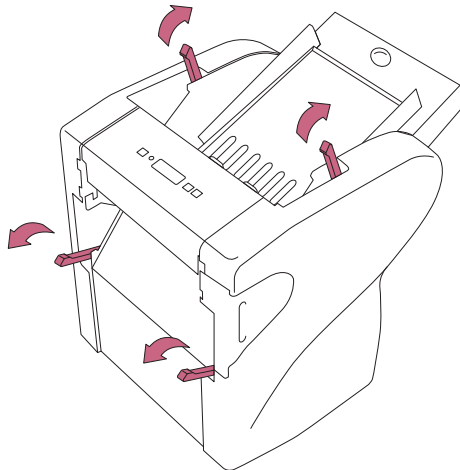

3

Insert fold Chutes face up and close Chute Lock Levers.

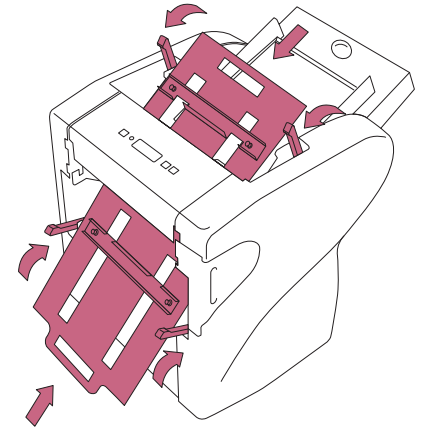

4

Insert Exit Tray. Line up the tray by putting the top pins in the top slots.

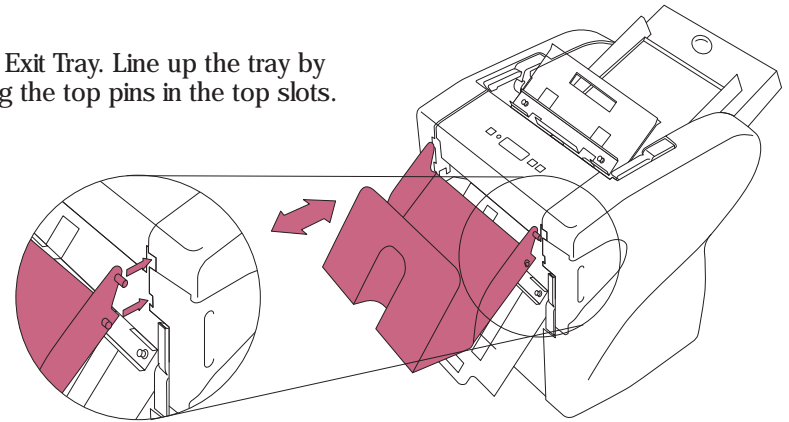

5

Plug in Power Cord and Turn On.

